

# classic plaza bench



The Classic Plaza Bench features slender battens made from eco-certified hardwood or aluminium, supported by stainless steel frames. Curved edges provide user comfort.

MCODE: CMP4

**DIMENSIONS:**

625W x 470H x various lengths (mm)  
 24 5/8" W x 18 1/2" H x various lengths

Select one box per category to specify your product.

**MOUNTING:**

- Surface Fixed
- Subsurface Fixed
- Core Drilled

**LENGTH:**

- 1750mm | 68 7/8"
- 2100mm | 82 5/8"
- Tailored

**LEG HEIGHT:**

- Standard
- Tall for Accessible Picnic Settings

**BATTEN:**

**Eco-certified Wood\***

- WoodPlus™ (Engineered Wood, FSC)
  - Raw
  - Oiled
- Hardwood, Oiled (PEFC)

**Low-carbon Aluminium\*\***

- Aluminium Woodgrain [See Colour Chart](#)
- Aluminium Powder Coated [See Colour Chart](#)
  - Single Colour
  - Multicolour
- Aluminium Anodised

\*Oiled wood needs re-oiling every 3 months, while raw wood can be left to silver naturally. For a fade-resistant, low-maintenance timber look, choose Aluminium Woodgrain (also known as Wood Without Worry™).

\*\*Low-carbon aluminium is produced using renewable energy instead of fossil fuels and is infinitely recyclable.

**FRAME:**

[See Colour Chart](#)

- Stainless 304 Powder Coated

**BATTEN ENDCAP COLOUR:**

- Match Batten
- Match Frame

**MOUNTING**

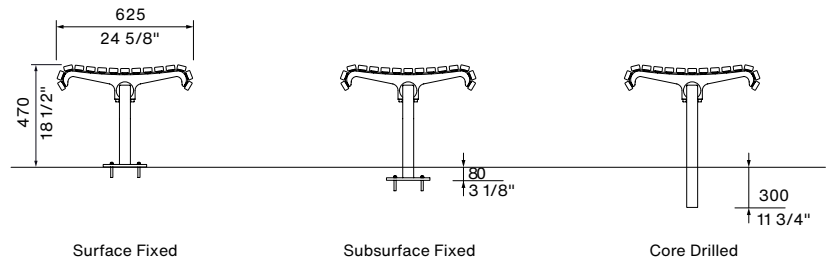

**LENGTH**

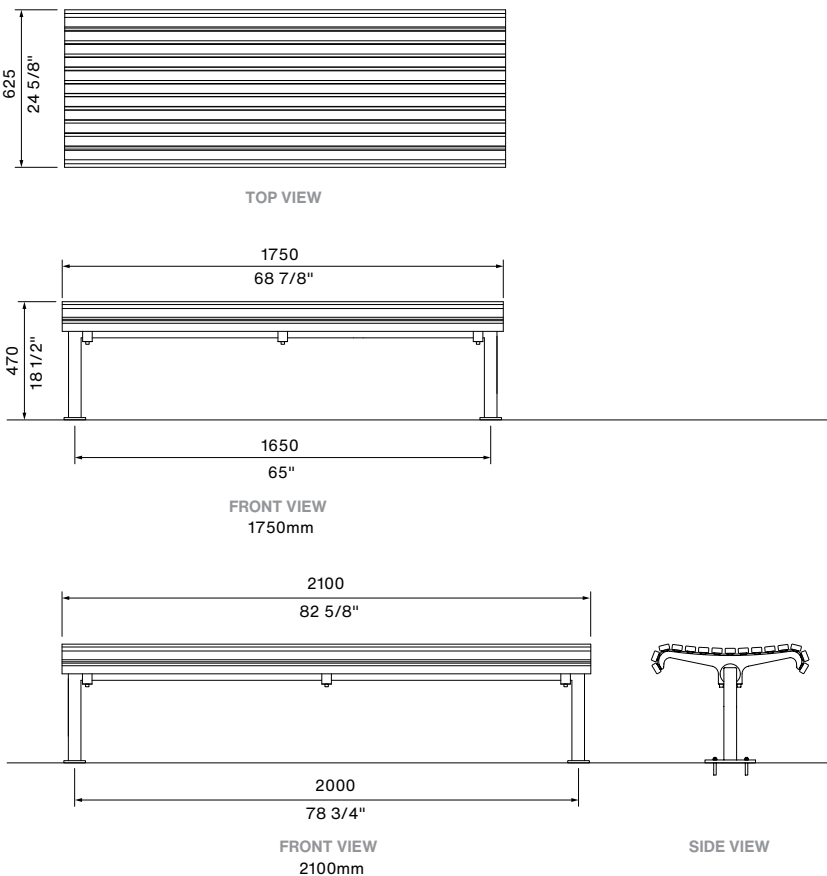

May 2026

# classic plaza bench

This is a  
carbon neutral  
product.



*Some options incur additional fees and lead time.*

*All products are made-to-order, quality-controlled and dispatched from the factory floor to ISO standards.*

## Need more information?

For a brochure, image gallery, CAD downloads, installation and maintenance guides, go to:

[streetfurniture.com/au/product/classic-plaza-bench/](https://streetfurniture.com/au/product/classic-plaza-bench/)

Quick links:

[streetfurniture.com/au/colour-chart/](https://streetfurniture.com/au/colour-chart/)

[streetfurniture.com/au/warranty/](https://streetfurniture.com/au/warranty/)

## BATTEN MAP

Refer to numbers to specify multicolour battens.

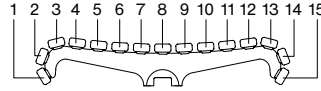

## BASEPLATE DETAIL

