

park table

street furniture™ technical sheets

<u>product name</u>	<u>mcode</u>	<u>page</u>
Park Table	PT7	2
Park DDA Table	PT9-DDA	4

park table



Outdoor table, perfect for picnics. Wide battens are bolted to cast aluminium frames.

DIMENSIONS:

670W x 700H x various lengths (mm)
 26 3/8" W x 27 1/2" H x various lengths

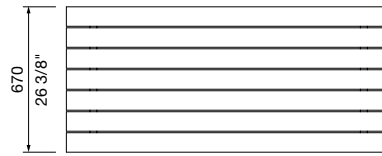

TOP VIEW

Select one box per category to specify your product.

LENGTH:

- 1500mm | 59"
- 1800mm | 70 7/8"
- 2500mm | 98 3/8"
- Tailored

FRAME:

[See colour chart](#)

- Cast aluminium powder coated

MOUNTING:

- Surface fixed
- Subsurface fixed
- Freestanding
- Tailored

BATTEN:

- Aluminium Woodgrain [See Colour Chart](#)
- Aluminium Powder Coated [See Colour Chart](#)
- Aluminium Anodised
- Eco-certified Hardwood Oiled*

**Sourced from certified managed forests (PEFC or FSC). Hardwood needs re-oiling every 3 months. For a wood look with low maintenance, choose Aluminium Woodgrain (also known as Wood Without Worry).*

BATTEN ENDCAP COLOUR:

- Match Batten
- Match Frame

Some options incur additional fees and lead time.

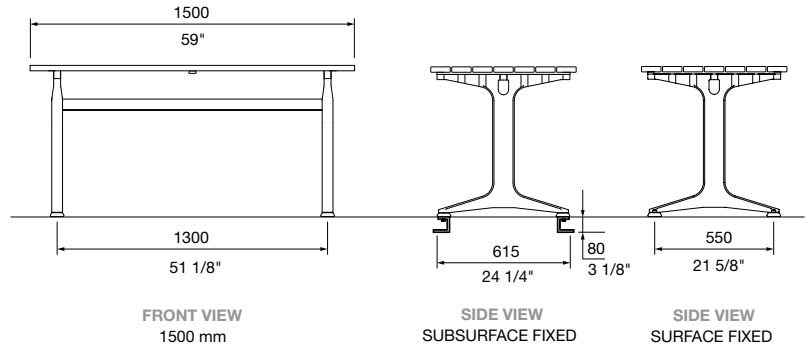

FRONT VIEW
1500 mm

SIDE VIEW
SUBSURFACE FIXED

SIDE VIEW
SURFACE FIXED

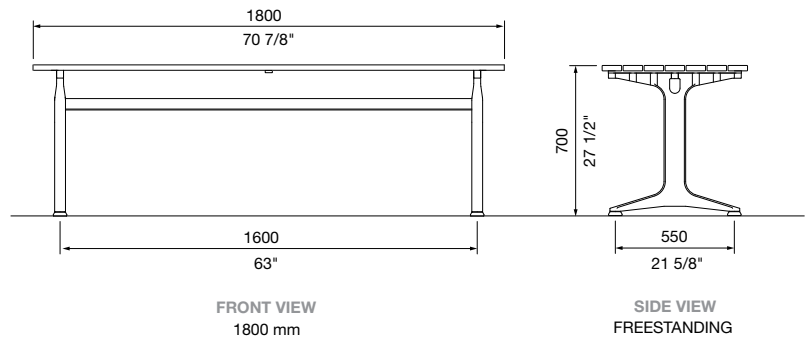

FRONT VIEW
1800 mm

SIDE VIEW
FREESTANDING

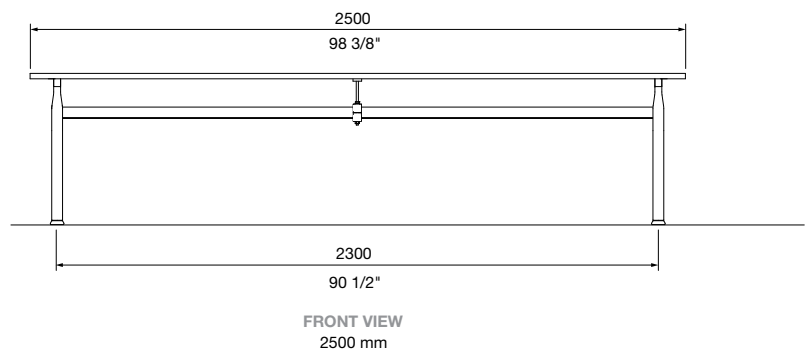

FRONT VIEW
2500 mm

park table

This is a carbon neutral product.



CHESS BOARD:

- None
- Chess Board 405x405(mm) | 15 15/16" x 15 15/16"

Need more information?

For a brochure, image gallery, CAD downloads, installation and maintenance guides, go to: streetfurniture.com/au/product/park-table/

Quick links:

- streetfurniture.com/au/colour-chart/
- streetfurniture.com/au/warranty/

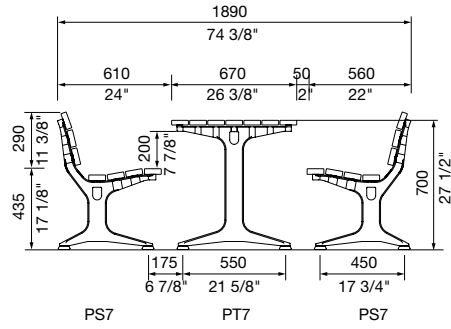

PS7 PT7 PS7
SIDE VIEW

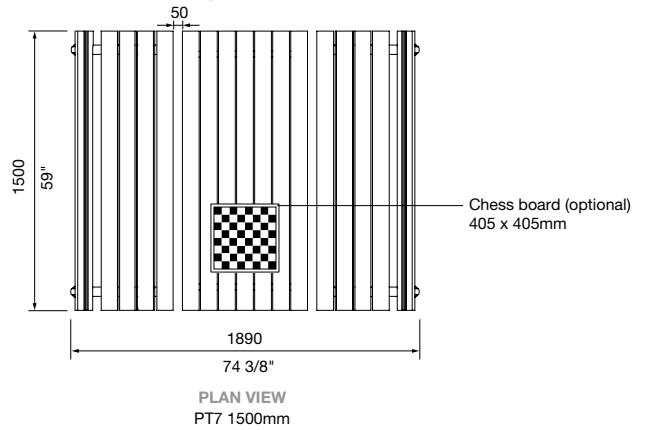

PLAN VIEW
PT7 1500mm

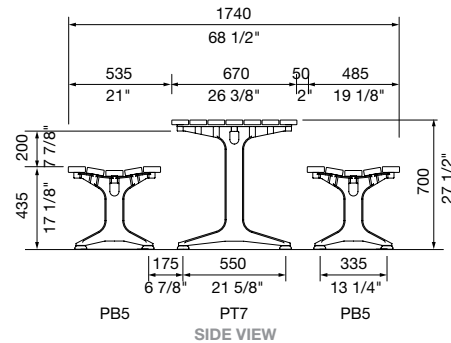

PB5 PT7 PB5
SIDE VIEW

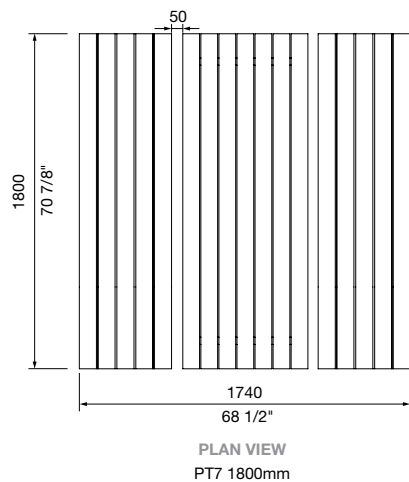

PLAN VIEW
PT7 1800mm

SETTING OPTIONS

park dda table

This is a carbon neutral product.



The Park DDA range features dedicated castings for accessible and comfortable seats, benches and table settings.

DIMENSIONS:

860W x 805H x various lengths (mm)
33 7/8" W x 31 3/4" H x various lengths

Select one box per category to specify your product.

LENGTH:

- 1800mm | 70 7/8"
- 2500mm | 98 3/8"
- Tailored

FRAME:

[See colour chart](#)

- Cast aluminium powder coated

MOUNTING:

- Surface fixed
- Subsurface fixed
- Tailored

BATTEN:

- Aluminium Woodgrain [See Colour Chart](#)
- Aluminium Powder Coated [See Colour Chart](#)
- Aluminium Anodised
- Eco-certified Hardwood Oiled*

*Sourced from certified managed forests (PEFC or FSC). Hardwood needs re-oiling every 3 months. For a wood look with low maintenance, choose Aluminium Woodgrain (also known as Wood Without Worry).

BATTEN ENDCAP COLOUR:

- Match Batten
- Match Frame

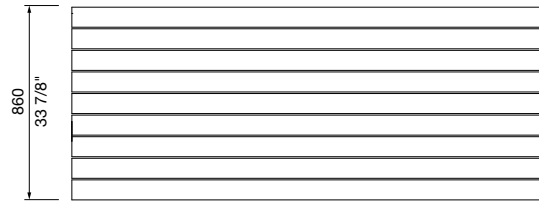

TOP VIEW
1800 mm

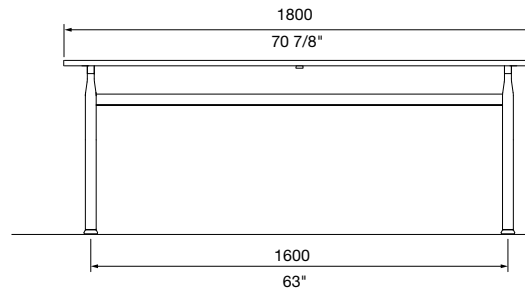

FRONT VIEW
1800 mm

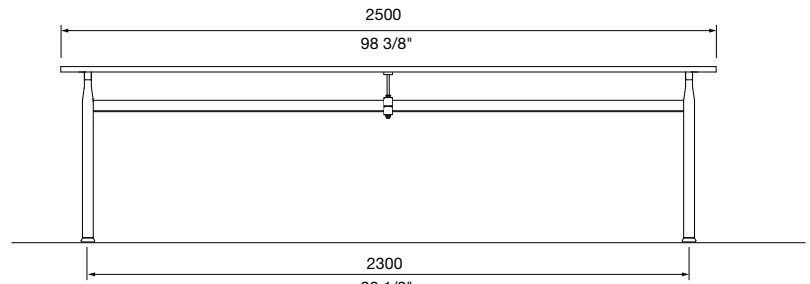

FRONT VIEW
2500 mm

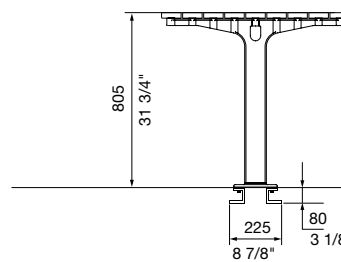

SIDE VIEW
SUBSURFACE FIXED

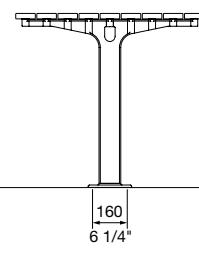

SIDE VIEW
SURFACE FIXED

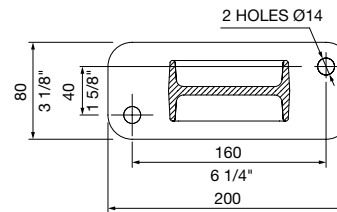

BASEPLATE DETAIL

park dda table



WHEELCHAIR ACCESS:

DDA tables specified with end-access (one end or both ends) must be fixed to the ground - surface fixed, subsurface fixed or core drilled.

- Side access
- Access from 1 end
- Access from both ends (only for 2500mm)

COMPATIBLE SEATING:

Refer to separate technical sheet.

- Park DDA Seat (PS7-DDA)
- Park DDA Bench (PB5-DDA)

CHESS BOARD:

- None
- Chess Board 405x405(mm) | 15 15/16" x 15 15/16"

Some options incur additional fees and lead time.

Need more information?

For a brochure, image gallery, CAD downloads, installation and maintenance guides, go to:

streetfurniture.com/au/product/park-table/

Quick links:

streetfurniture.com/au/colour-chart/

streetfurniture.com/au/warranty/

