

arquá station

This is a carbon neutral product.



Features the Arquá Fountain and Refill Pole to facilitate drinking and easy container refilling.



This product is certified under the WaterMark standard WMTS105:2016.

DIMENSIONS:

1520L x 450W x 1495H (mm)
59 7/8" L x 17 3/4" W x 58 7/8" H

Select one box per category to specify your product.

BODY:

See Colour Chart

- Fountain Stainless 304 Powder Coated, Refill Pole Aluminium Powder Coated
- Both Stainless 316 Powder Coated
- Both Stainless 316 Electropolished

HEIGHT:

- 1125mm (Fountain) + 1495mm (Refill Pole)
- 780mm (Fountain) + 1495mm (Refill Pole)
- Tailored

SPOUT AND BUTTON (for Refill Pole):

- Single Outlet, Stainless 316 Bright Polished
- Double Outlet, Stainless 316 Bright Polished

SIGNAGE (for Refill Pole):

Not compatible with a Textura powder coated finish.

- UV Vinyl 'Tap'
- UV Vinyl 'Filtered'
- Tailored

FILTER (for Refill Pole):

- No
- Yes

SPOUT HEIGHT (for Refill Pole):

- 875mm | 34 1/2" (standard)

Some options incur additional fees and lead time.

The Arquá fountain range adheres to Australian drinking water guidelines. Drinking water connected must be at a 7pH level for human consumption. Recommended operating temperature range from 5°C to maximum 60°C. Recommended operating pressure is minimum 0.5 bar (50Kpa) to maximum 5 bar (500Kpa). Installer must check pressure from the relief valve as required.

Need more information?

For a brochure, image gallery, CAD downloads, installation and maintenance guides, go to: streetfurniture.com/au/product/arqua-station/

Quick links:

streetfurniture.com/au/colour-chart/
streetfurniture.com/au/warranty/

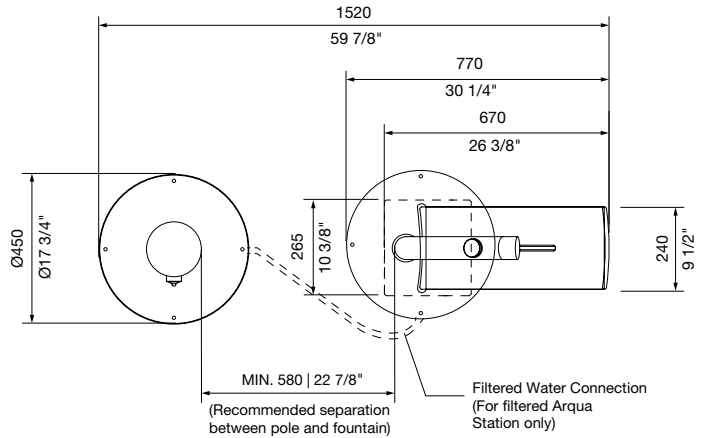

TOP VIEW

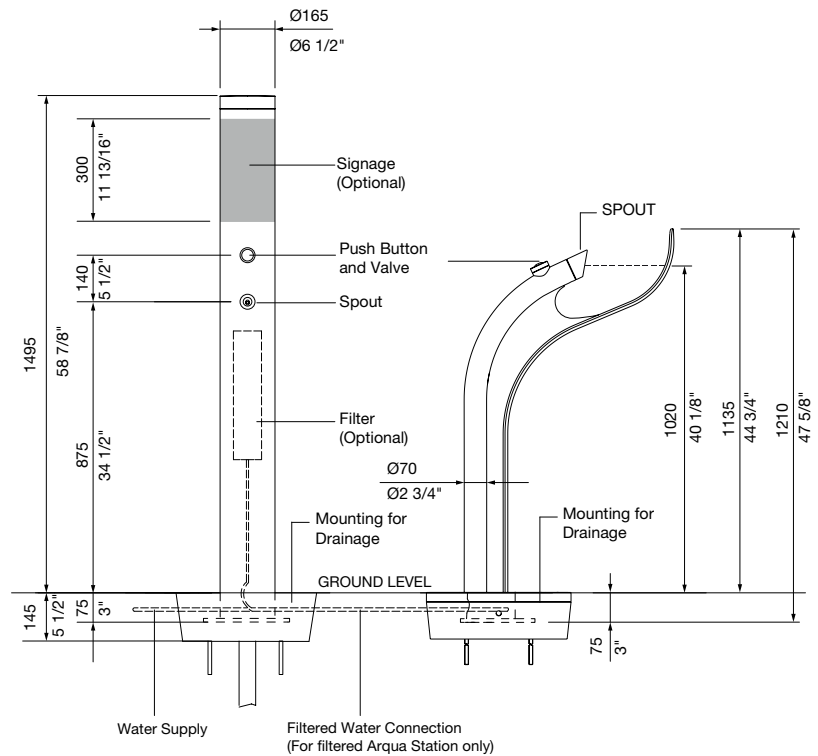

FRONT VIEW



UV Vinyl 'Tap'



UV Vinyl 'Filtered'

SIGNAGE OPTIONS